

1. PARKING ONLY ON ONE SIDE OF STREET.
2. NO PARKING SIGNS SHALL BE POSTED FOR SIDE WITHOUT PARKING.
3. MAY ALSO MARK CURBS IN RED FOR NO PARKING.

### 4+ LOTS (NO PARKING 1 SIDE OF STREET)

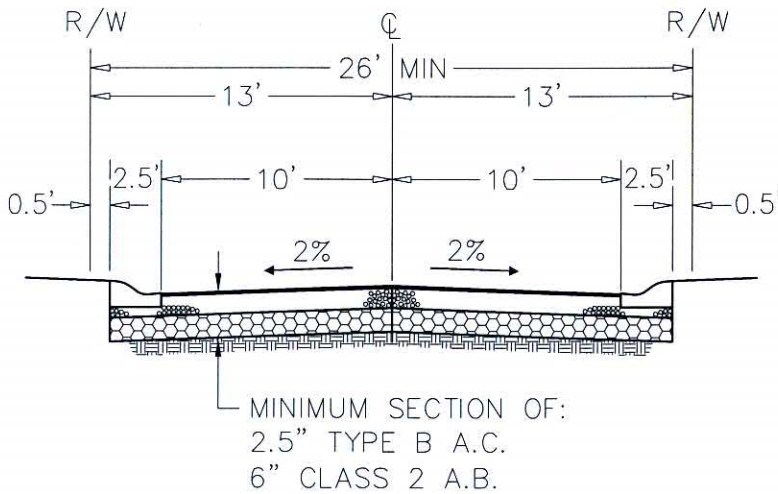

1. SIGNS SHALL BE POSTED FOR NO PARKING ON BOTH SIDES OF STREET.
2. MAY ALSO MARK CURBS IN RED FOR NO PARKING.

### 2-3 LOTS (NO ON-STREET PARKING)

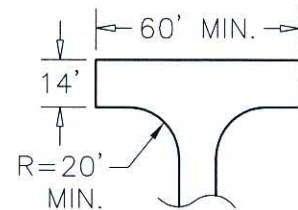
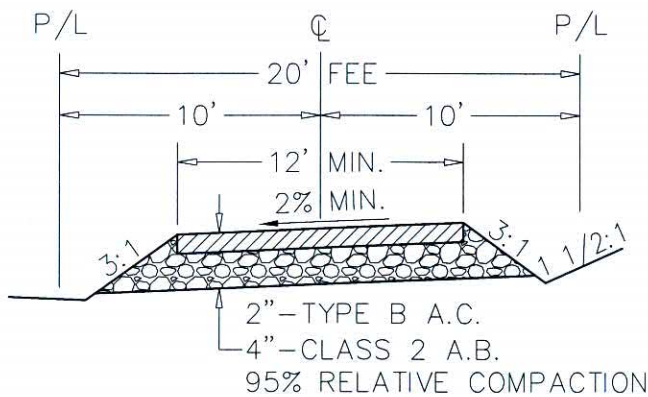

**HAMMER HEAD "T"**  
IN CONFORMANCE WITH FIRE DEPARTMENT REQUIREMENTS

### FLAG LOT (1 LOT)

**NOTES:**

1. WHEN 2 OR MORE RESIDENCES USE THE ACCESS ROAD, A HAMMER HEAD "T" OR OTHER TURN-AROUND AREA APPROVED BY THE FIRE DEPT. AND THE PUBLIC WORKS DEPT. SHALL BE PROVIDED.

YUBA COUNTY DEPARTMENT OF PUBLIC WORKS	
URBAN IN-FILL DEVELOPMENT PRIVATE ACCESS ROADS	
APPROVED BY: 	DATE: 9/3/09
130	